



Maximum Performance



ACL80K

ACL80K IS A GREAT SOLUTION WITH SAME FOOT PRINT BUT HIGHER IRONING CAPACITY AND LESS ENERGY CONSUMPTION

FEATURES AND BENEFITS

CHEST

- One piece super flexible laser welding chests with 278°, 3/4 wrap up the roll for optimal ironing contact
- Self-adjusted chest applies pressure always equally over entire width and length of the roll that makes linen being ironed equal quality
- Chest heated by circulated thermal oil moving in inside the chests. It makes the temperature even along full chest width. No trouble of overheated spots.
- Self contained thermal oil heating and circulation system offers accurate temperature control, easy installation and start up
- The unique ventilation of chest improves efficiency up to 25% capacity

ROLL

- Perforated steel roll with under springing and M-Aramid felt 800 gr/m² padding
- Suction through the roll to ventilate moisture
- Fully enclosed planetary gearbox mounted directly onto the roll
- Variable speed by frequency inverter drive
- Ultra high ironing speed up to 36 m/min

CONTROL

- Standard 7,5" touch screen with 50 programs
- Speed regulation and modulating burner included

OPTIONS

- Foot pedal for easy stop and start
- Perforated vacuum feeding bands for easy feeding linen

CHEST HEATED IRONERS - ONE ROLL; SPECIAL DEEPER CHEST

TYPE		ACL80K-25	ACL80K-30	ACL80K-33	ACL80K-35
Roll diameter	mm	800	800	800	800
Working width	mm	2500	3000	3300	3500
Ironing speed	m/min	9-36	9-36	9-36	9-36
Ironing heating surface	m ²	4,85	5,82	6,40	6,79
Fan motor	kW	1,1	1,1	1,1	1,1
Roll motor	kW	11	11	11	11
Air outlet diameter	mm	Ø125	Ø125	Ø125	Ø125
Hydraulic pump motor	kW	0,37	0,37	0,37	0,37
Oil circulation pump	kW	3	3	3	3
Exhaust feeding belt	kW	1,1	1,1	1,1	1,1
Voltage		3x380-415V +TN-C 50Hz	3x380-415V +TN-C 50Hz	3x380-415V +TN-C 50Hz	3x380-415V +TN-C 50Hz
GAS HEATING					
Gas connection	inch	¼"	¼"	¼"	¼"
Gas burner	kW	189	189	189	189
Heat exchanger evacuation	mm	Ø125	Ø125	Ø125	Ø125
Ironing capacity @moisture retention 50%	kg/hr	308	370	405	430
ELECTRIC HEATING					
Heating element	kW	100	120	150	165
Ironing capacity @moisture retention 50%	kg/hr	308	370	405	430
DIMENSIONS					
Width	mm	3735	4235	4535	4735
Depth	mm	1820	1820	1820	1820
Height	mm	1655	1655	1655	1655
Net weight	kg	2800	3100	3250	3450
SHIPPING DIMENSIONS					
Width	mm	3800	4300	4600	4800
Depth	mm	2300	2300	2300	2300
Height	mm	1800	1800	1800	1800
Gross weight	kg	2850	3150	3300	3500

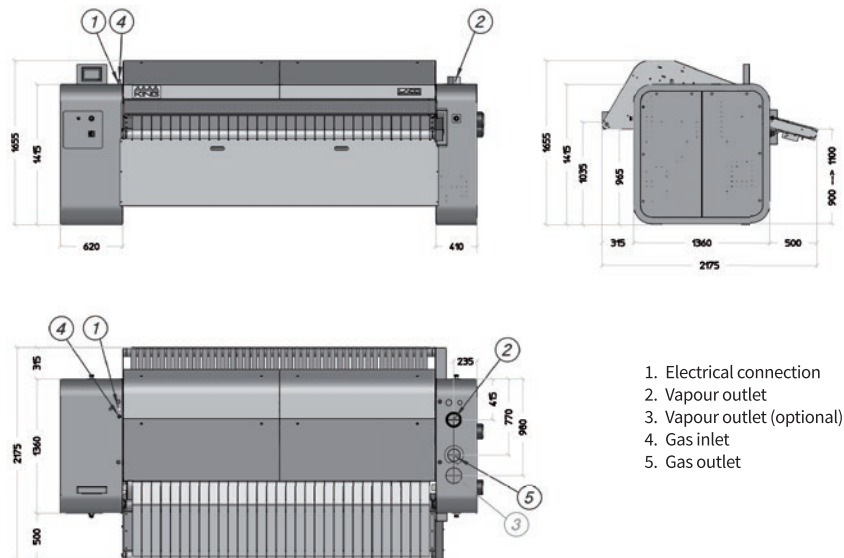

TO LEARN MORE, OR TO FIND A DISTRIBUTOR IN YOUR AREA, VISIT UNIMAC.COM
ALLIANCE LAUNDRY SYSTEMS - SHEPARD ST, RIPON WI 54971 - +1 800 587 5458

Consult your UniMac® distributor for details. For the most accurate information, the installation guide should be used for all design and construction purposes. Due to continuous product improvements, design and specifications subject to change without notice. The quality management systems at Alliance Laundry Systems' Ripon facility has been registered to ISO 9001:2008.

©2018 Alliance Laundry Systems LLC.

UniMac® by Alliance Laundry Systems